

WPLE

直角行星减速机  
轻巧  
经济性较高

WPLE 在不断将经济型产品系列的优势发扬光大。凭借其紧凑但有力的结构型式，它成为了动态多轴系统的理想选择。我们的直角减速机终生润滑免维护，安装时简单易操作，堪称性价比之王。

The versatile right angle planetary gearbox with lower weight and appealing cost effectiveness

The WPLE is a consistent continuation of the benefits offered by the Economy Line. With its compact, but powerful design, it is ideal for dynamic multiple axis systems. Our right angle gearbox features lifetime lubrication, is easy to install, all this at an unrivalled price-performance ratio.

额定扭矩  
Nominal output torque **5 - 260 Nm**

回程间隙  
Torsional backlash **11 - 28 arcmin**

倾斜力矩  
Tilting moment **5 - 101 Nm**

防护等级  
Protection class **IP54**

结构尺寸  
Frame sizes

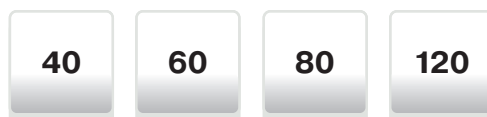

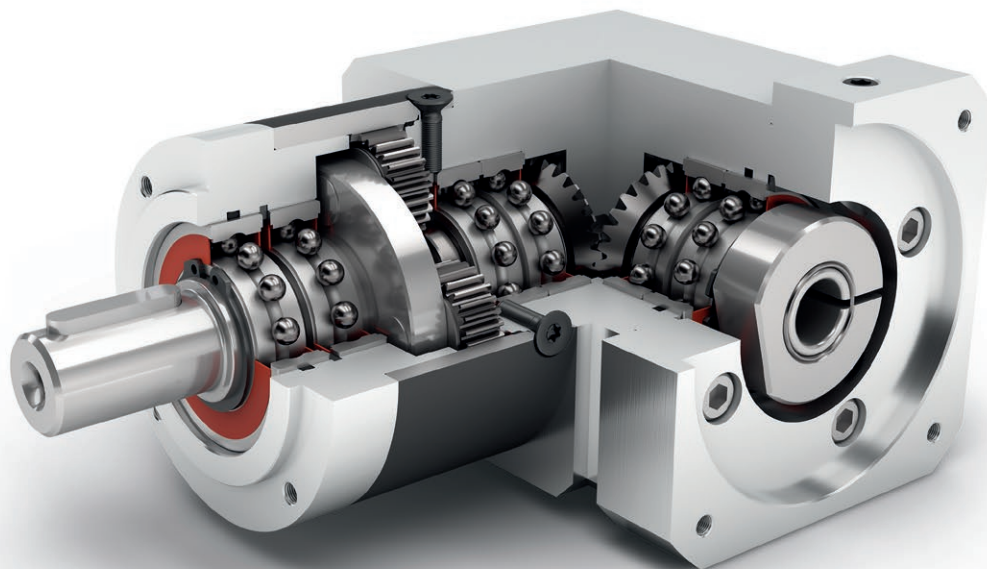

Economy Line  
Economy Line



转角型减速机  
Right angle gearbox



直齿  
Spur gear

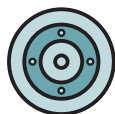

圆形输出法兰  
Round type output flange



多样的变速比 (i=3 至 i=512)  
High ratio variety i=3 up to i=512



旋转方向 同方向  
Equidirectional rotation



锥齿轮 角度级  
Bevel gear right angle stage



低摩擦深沟球轴承  
Low-friction deep groove ball bearings



行星齿轮架 (片状结构)  
Planet carrier in disc design

Code	减速机参数	Gearbox characteristics			WPLE040	WPLE060	WPLE080	WPLE120	p <sup>(1)</sup>
	使用寿命 (L <sub>10h</sub> )	Service life (L <sub>10h</sub> )	t <sub>L</sub>	h	20.000				
	T <sub>2N</sub> × 0,88 时的使用寿命	Service life at T <sub>2N</sub> × 0,88			30.000				
	满载时效率 <sup>(2)</sup>	Efficiency at full load <sup>(2)</sup>	η	%	95				1
					94				2
					88				3
	最低工作温度	Min. operating temperature	T <sub>min</sub>	°C	-25				
	最高工作温度	Max. operating temperature	T <sub>max</sub>		90				
	防护等级	Protection class			IP54				
S	标准润滑	Standard lubrication			润滑脂 (终生润滑) / Grease (lifetime lubrication)				
F	食品级润滑	Food grade lubrication			润滑脂 (终生润滑) / Grease (lifetime lubrication)				
L	低温润滑 <sup>(3)</sup>	Low temperature lubrication <sup>(3)</sup>			润滑脂 (终生润滑) / Grease (lifetime lubrication)				
	安装位置	Installation position			任意 / Any				
S	标准回程间隙	Standard backlash	j <sub>t</sub>	arcmin	< 21	< 16	< 13	< 11	1
					< 25	< 18	< 15	< 13	2
					< 28	< 21	< 17	< 15	3
	抗扭刚度 <sup>(2)</sup>	Torsional stiffness <sup>(2)</sup>	c <sub>g</sub>	Nm / arcmin	0,5 - 0,8	1,5 - 2,3	4,0 - 7,9	9,9 - 17,5	1
					0,7 - 1,0	2,2 - 2,7	6,9 - 9,6	16,4 - 20,5	2
					0,8 - 1,0	2,2 - 2,7	7,4 - 9,9	16,4 - 21,0	3
					0,5	1,7	4,4	12	1
	减速机重量	Gearbox weight	m <sub>G</sub>	kg	0,6	1,9	5	14	2
					0,7	2,1	5,5	16	3
					箱体: 钢 - 热处理后氧化 (黑色) Housing: Steel - heat-treated and post-oxidized (black)				
S	标准的箱体表面	Standard surface							
	运行噪音 <sup>(4)</sup>	Running noise <sup>(4)</sup>	Q <sub>g</sub>	dB(A)	68	70	73	75	
	基于减速机输入法兰的最大弯矩 <sup>(5)</sup>	Max. bending moment based on the gearbox input flange <sup>(5)</sup>	M <sub>b</sub>	Nm	2	5	10,5	26	

输出轴载荷	Output shaft loads			WPLE040	WPLE060	WPLE080	WPLE120	p <sup>(1)</sup>
20,000 h 的径向力 <sup>(6)(7)</sup>	Radial force for 20,000 h <sup>(6)(7)</sup>	F <sub>r20.000h</sub>	N	200	400	750	1750	
20,000 h 的轴向力 <sup>(6)(7)</sup>	Axial force for 20,000 h <sup>(6)(7)</sup>	F <sub>a20.000h</sub>		200	500	1000	2500	
30,000 h 的径向力 <sup>(6)(7)</sup>	Radial force for 30,000 h <sup>(6)(7)</sup>	F <sub>r30.000h</sub>		160	340	650	1500	
30,000 h 的轴向力 <sup>(6)(7)</sup>	Axial force for 30,000 h <sup>(6)(7)</sup>	F <sub>a30.000h</sub>		160	450	900	2100	
最大径向力 <sup>(7)(8)</sup>	Maximum radial force <sup>(7)(8)</sup>	F <sub>r Stat</sub>		200	700	1250	2000	
最大轴向力 <sup>(7)(8)</sup>	Maximum axial force <sup>(7)(8)</sup>	F <sub>a Stat</sub>		240	800	1600	3800	
20,000 h 倾斜力矩 <sup>(6)(8)</sup>	Tilting moment for 20,000 h <sup>(6)(8)</sup>	M <sub>K20.000h</sub>	Nm	5	14	31	101	
30,000 h 倾斜力矩 <sup>(6)(8)</sup>	Tilting moment for 30,000 h <sup>(6)(8)</sup>	M <sub>K30.000h</sub>		4	12	27	86	

转动惯量	Moment of inertia			WPLE040	WPLE060	WPLE080	WPLE120	p <sup>(1)</sup>
转动惯量 <sup>(2)</sup>	Mass moment of inertia <sup>(2)</sup>	J	kgcm <sup>2</sup>	0,032 - 0,049	0,221 - 0,357	0,910 - 1,273	1,820 - 2,846	1
				0,032 - 0,048	0,222 - 0,350	0,916 - 1,232	1,855 - 2,773	2
				0,032 - 0,047	0,222 - 0,232	0,916 - 1,209	1,854 - 2,681	3

(1) 减速机级数  
 (2) 传动比相关的数值可在 Tec Data Finder 中检索 - www.neugart.com  
 (3) T<sub>min</sub> = -40°C. 理想运行温度最高为 50°C  
 (4) 距离减速机 1 m 时; 在输入转速为 n<sub>1</sub>=3000 min<sup>-1</sup> 且无负荷时测得; i=5  
 (5) 最大发动机重量\* (单位: kg) = 0.2 × M<sub>b</sub> / 发动机长度 (单位: m)  
 \* 发动机重量对称分布  
 \* 水平和固定的安装位置  
 (6) 数据以 n<sub>2</sub>=100 min<sup>-1</sup> 的输出轴转速为准。  
 (7) 基于输出轴末端  
 (8) 更改 T<sub>2N</sub>, F<sub>r</sub>, F<sub>a</sub> 以及周期和轴承使用寿命时, 数值存在偏差 (部分较高)。利用 NCP 针对应用进行专门设计 - www.neugart.com

(1) Number of stages  
 (2) The ratio-dependent values can be retrieved in Tec Data Finder - www.neugart.com  
 (3) T<sub>min</sub> = -40°C. Optimal operating temperature max. 50°C  
 (4) Sound pressure level from 1 m, measured on input running at n<sub>1</sub>=3000 rpm no load; i=5  
 (5) Max. motor weight\* in kg = 0.2 × M<sub>b</sub> / motor length in m  
 \* with symmetrically distributed motor weight  
 \* with horizontal and stationary mounting  
 (6) These values are based on an output shaft speed of n<sub>2</sub>=100 rpm  
 (7) Based on center of output shaft  
 (8) Other (sometimes higher) values following changes to T<sub>2N</sub>, F<sub>r</sub>, F<sub>a</sub>, cycle, and service life of bearing. Application specific configuration with NCP - www.neugart.com

输出扭矩	Output torques			WPLE040	WPLE060	WPLE080	WPLE120	$i^{(1)}$	$p^{(2)}$
额定输出扭矩 <sup>(3)(4)</sup>	Nominal output torque <sup>(3)(4)</sup>	$T_{2N}$	Nm	4,5	14	40 <sup>(5)</sup>	80 <sup>(5)</sup>	3	1
				6	19	53 <sup>(5)</sup>	105 <sup>(5)</sup>	4	
				7,5	24	67 <sup>(5)</sup>	130 <sup>(5)</sup>	5	
				8,5	25	65	135	7	
				6	18	50	120	8	
				5	15	38	95	10	
				16,5 <sup>(5)</sup>	44 <sup>(5)</sup>	130 <sup>(5)</sup>	210 <sup>(5)</sup>	9	2
				20 <sup>(5)</sup>	44	120 <sup>(5)</sup>	260 <sup>(5)</sup>	12	
				18 <sup>(5)</sup>	44	110	230	15	
				20 <sup>(5)</sup>	44	120	260	16	
				20 <sup>(5)</sup>	44	120	260	20	
				18	40	110	230	25	
				20	44	120	260	32	3
				18	40	110	230	40	
				7,5	18	50	120	64	
				20	44	110	260	60	
				20	44	120	260	80	
				20	44	120	260	100	
				18	44	110	230	120	3
				20	44	120	260	160	
				18	40	110	230	200	
				20	44	120	260	256	
				18	40	110	230	320	
				7,5	18	50	120	512	
最大输出扭矩 <sup>(4)(6)</sup>	Max. output torque <sup>(4)(6)</sup>	$T_{2max}$	Nm	7	22	64	128	3	1
				10	30	85	168	4	
				12	38	107	208	5	
				13,5	40	104	216	7	
				10	29	80	192	8	
				8	24	61	152	10	
				26	70	208	336	9	2
				32	70	192	416	12	
				29	70	176	368	15	
				32	70	192	416	16	
				32	70	192	416	20	
				29	64	176	368	25	
				32	70	192	416	32	3
				29	64	176	368	40	
				12	29	80	192	64	
				32	70	176	416	60	
				32	70	192	416	80	
				32	70	192	416	100	
				29	70	176	368	120	3
				32	70	192	416	160	
				29	64	176	368	200	
				32	70	192	416	256	
				29	64	176	368	320	
				12	29	80	192	512	

WPLE

(1) 传动比 ( $i=n_1/n_2$ )  
 (2) 减速机级数  
 (3) 利用 NCP 针对应用进行专门设计 - www.neugart.com  
 (4) 平键 (代码 „A“)时的数值: 针对交变载荷  
 (5)  $T_{2N}$  作用时 寿命不是10.000 h  
 (6) 允许输出轴转动30.000转; 参见第 142页

(1) Ratios ( $i=n_1/n_2$ )  
 (2) Number of stages  
 (3) Application specific configuration with NCP - www.neugart.com  
 (4) Values for feather key (code "A"): for repeated load  
 (5) Different service life: 10,000 h at  $T_{2N}$   
 (6) 30,000 rotations of the output shaft permitted; see page 143

输出扭矩	Output torques			WPLE040	WPLE060	WPLE080	WPLE120	i <sup>(1)</sup>	p <sup>(2)</sup>
急停扭矩 <sup>(3)</sup>	Emergency stop torque <sup>(3)</sup>	T <sub>2Stop</sub>	Nm	22,5	66	180	360	3	1
				28	86	240	474	4	
				35	80	220	500	5	
				26	80	178	340	7	
				27	80	190	380	8	
				25	70	170	430	10	
				33	88	260	500	9	2
				40	88	240	520	12	
				36	88	220	500	15	
				40	88	240	520	16	
				40	88	240	520	20	
				36	80	220	500	25	
				40	88	240	520	32	3
				36	80	220	500	40	
				27	80	190	380	64	
				40	88	220	520	60	
				40	88	240	520	80	
				40	88	240	520	100	
				36	88	220	500	120	3
				40	88	240	520	160	
				36	80	220	500	200	
				40	88	240	520	256	
				36	80	220	500	320	
				27	80	190	380	512	

输入转速	Input speeds			WPLE040	WPLE060	WPLE080	WPLE120	i <sup>(1)</sup>	p <sup>(2)</sup>				
T <sub>2N</sub> 和 S1 时的平均热输入转速 <sup>(4)(5)</sup>	Average thermal input speed at T <sub>2N</sub> and S1 <sup>(4)(5)</sup>	n <sub>1N</sub>	min <sup>-1</sup>	5000	4500 <sup>(6)</sup>	3500 <sup>(6)</sup>	2850 <sup>(6)</sup>	3	1				
				5000	4500 <sup>(6)</sup>	3550 <sup>(6)</sup>	2950 <sup>(6)</sup>	4					
				5000	4500 <sup>(6)</sup>	3600 <sup>(6)</sup>	3050 <sup>(6)</sup>	5					
				5000	4500	4000 <sup>(6)</sup>	3500 <sup>(6)</sup>	7					
				5000	4500	4000 <sup>(6)</sup>	3500 <sup>(6)</sup>	8					
				5000	4500	4000	3500	10					
				5000	4500 <sup>(6)</sup>	3250 <sup>(6)</sup>	2950 <sup>(6)</sup>	9	2				
				5000	4500 <sup>(6)</sup>	3850 <sup>(6)</sup>	3050 <sup>(6)</sup>	12					
				5000	4500	4000 <sup>(6)</sup>	3500 <sup>(6)</sup>	15					
				5000	4500	4000 <sup>(6)</sup>	3450 <sup>(6)</sup>	16					
				5000	4500	4000 <sup>(6)</sup>	3500 <sup>(6)</sup>	20					
				5000	4500	4000	3500 <sup>(6)</sup>	25					
				最高机械输入转速 <sup>(4)</sup>	Max. mechanical input speed <sup>(4)</sup>	n <sub>1Limit</sub>	min <sup>-1</sup>	5000	4500	4000	3500	32	3
								5000	4500	4000	3500	40	
								5000	4500	4000	3500	64	
								5000	4500	4000	3500	80	
								5000	4500	4000	3500	100	
								5000	4500	4000	3500	120	
								5000	4500	4000	3500	160	
								5000	4500	4000	3500	200	
								5000	4500	4000	3500	256	
								5000	4500	4000	3500	320	
								5000	4500	4000	3500	512	

(1) 传动比 (i=n<sub>1</sub>/n<sub>2</sub>)

(2) 减速机级数

(3) 允许 1000 次

(4) 利用 NCP 针对应用设计转速 - www.neugart.com

(5) 定义请参见第 142 页

(6) 在 50% T<sub>2N</sub> 输出和 S1 模式下的平均热传动转速

(1) Ratios (i=n<sub>1</sub>/n<sub>2</sub>)

(2) Number of stages

(3) Permitted 1000 times

(4) Application-specific speed configurations with NCP - www.neugart.com

(5) See page 143 for the definition

(6) Average thermal input speed at 50% T<sub>2N</sub> and S1

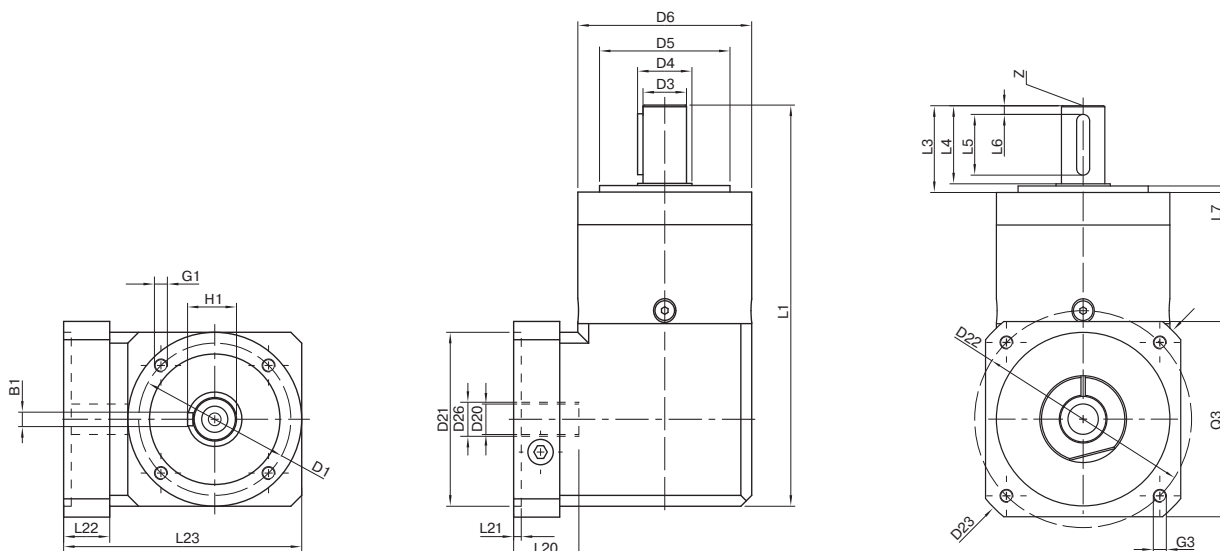

图示为带平键的 WPLE080 / 1 级 / 附带平键的输出轴 / 19 mm 锁紧系统 / 适配电机法兰 - 2 件式 - 正方形通用法兰 / B5 电机法兰类型  
 Drawing corresponds to a WPLE080 / 1-stage / output shaft with feather key / 19 mm clamping system / motor adaptation - 2-part - square universal flange / B5 flange type motor  
 所有其它变量可在 [www.neugart.com](http://www.neugart.com) 下 Tec Data Finder 中检索 - All other variants can be retrieved in the Tec Data Finder at [www.neugart.com](http://www.neugart.com)

几何尺寸 <sup>(1)</sup>	Geometry <sup>(1)</sup>			WPLE040	WPLE060	WPLE080	WPLE120	z <sup>(2)</sup>	Code
输出端安装孔节圆直径	Pitch circle diameter output	D1		34	52	70	100		
输出轴直径	Shaft diameter output	D3	h7	10	14	20	25		
输出轴轴肩直径	Shaft collar output	D4		12	17	25	35		
输出端定位凸台直径	Centering diameter output	D5	h7	26	40	60	80		
箱体直径	Housing diameter	D6		40	60	80	115		
安装螺纹 x 深度	Mounting thread x depth	G1	4x	M4x6	M5x8	M6x10	M10x16		
总长	Total length	L1		110	147	184	249,5	1	
				123	159,5	201,5	277	2	
				135,5	172	219	304,5	3	
输出轴轴长	Shaft length output	L3		26	35	40	55		
输出端定位凸台深度	Centering depth output	L7		2	3	3	4		
最小总高度	Min. overall height	L23		62	86	110	146		
输入端锁紧系统直径	Clamping system diameter input	D26		更多信息见第 131 页 More information on page 131					
电机轴直径 j6/k6	Motor shaft diameter j6/k6	D20		具体尺寸视电机/减速机法兰而定。 可以在 <a href="http://www.neugart.com">www.neugart.com</a> 下 Tec Data Finder. 中针对每个电机适配电机特有的输入法兰几何尺寸  The dimensions vary with the motor/gearbox flange. The input flange dimensions can be retrieved for each specific motor in Tec Data Finder at <a href="http://www.neugart.com">www.neugart.com</a>					
最大允许的电机轴长	Max. permis. motor shaft length	L20							
最小允许的电机轴长	Min. permis. motor shaft length								
输入端定位凹槽直径	Centering diameter input	D21							
输入端定位凹槽深度	Centering depth input	L21							
输入端安装孔节圆直径	Pitch circle diameter input	D22							
输入法兰长度	Motor flange length	L22							
输入法兰对角线尺寸	Diagonal dimension input	D23							
安装螺纹 x 深度	Mounting thread x depth	G3	4x						
输入端法兰外方	Flange cross section input	Q3	■						
附带平键的输出轴 (DIN 6885-1)	Output shaft with feather key (DIN 6885-1)			A 3x3x18	A 5x5x25	A 6x6x28	A 8x7x40		A
平键宽度 (DIN 6885-1)	Feather key width (DIN 6885-1)	B1		3	5	6	8		
含平键在内的轴高 (DIN 6885-1)	Shaft height including feather key (DIN 6885-1)	H1		11,2	16	22,5	28		
到轴肩的距离	Shaft length from shoulder	L4		23	30	36	50		
平键长度	Feather key length	L5		18	25	28	40		
到轴端的距离	Distance from shaft end	L6		2,5	2,5	4	5		
中心孔 (DIN 332, DR 形)	Center hole (DIN 332, type DR)	Z		M3x9	M5x12,5	M6x16	M10x22		
光滑输出轴	Smooth output shaft								B
到轴肩的距离	Shaft length from shoulder	L4		23	30	36	50		

<sup>(1)</sup> 所有的尺寸单位为mm  
<sup>(2)</sup> 减速机级数

<sup>(1)</sup> Dimensions in mm  
<sup>(2)</sup> Number of stages