

PLFE

The shortest planetary gearbox with the highest torsional stiffness and flange output shaft

There's no such thing as too short: The **PLFE** is our planetary gearbox with compact flange output shaft. You save more than a third of the space and gain a significantly higher torsional stiffness. Due to its standardized flange interface, it is especially easy to install. The integrated dowel hole provides additional secureness during fitting.

Nominal output torque **15 - 260 Nm**

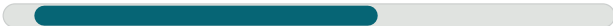

Torsional backlash **7 - 12 arcmin**



Tilting moment **12 - 109 Nm**

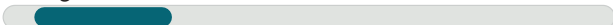

Protection class **IP54**



Frame sizes

64 90 110



Economy Line

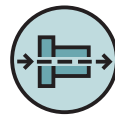

Coaxial gearbox



Equidirectional rotation



Spur gear



Extra large round type output flange



Low-friction deep groove ball bearings



Flange output shaft (ISO 9409)



Planet carrier in disc design



PLFE

Code	Gearbox characteristics			PLFE064	PLFE090	PLFE110	p ⁽¹⁾
	Service life (L _{10h})	t _L	h	30,000			
	Efficiency at full load ⁽²⁾	η	%	98			1
				97			2
	Min. operating temperature	T _{min}	°C	-25 (-13)			
	Max. operating temperature	T _{max}	(°F)	90 (194)			
	Protection class			IP54			
S	Standard lubrication			Grease (lifetime lubrication)			
F	Food grade lubrication			Grease (lifetime lubrication)			
L	Low temperature lubrication ⁽³⁾			Grease (lifetime lubrication)			
	Installation position			Any			
S	Standard backlash	j _t	arcmin	< 10	< 7	< 7	1
				< 12	< 9	< 9	2
	Torsional stiffness ⁽²⁾	c _g	Nm/arcmin (lb _f .in/ arcmin)	5.5 - 11.0 (49 - 97)	16.3 - 33.5 (144 - 296)	36.0 - 72.0 (319 - 637)	1
				5.1 - 11.9 (45 - 105)	15.9 - 39.5 (141 - 350)	29.5 - 88.0 (261 - 779)	2
	Gearbox weight	m _G	kg (lb _m)	1.1 (2.4)	2.9 (6.4)	7 (15.4)	1
				1.5 (3.3)	3.3 (7.3)	9 (19.8)	2
S	Standard surface			Housing: Steel – heat-treated and post-oxidized (black)			
	Running noise ⁽⁴⁾	Q _g	dB(A)	58	60	65	
	Max. bending moment based on the gearbox input flange ⁽⁵⁾	M _b	Nm (lb _f .in)	8 (71)	16 (142)	40 (354)	

Output shaft loads			PLFE064	PLFE090	PLFE110	p ⁽¹⁾
Radial force for 20,000 h ⁽⁶⁾⁽⁷⁾	F _{r 20.000 h}	N (lb _f)	550 (124)	1400 (315)	2400 (540)	
Axial force for 20,000 h ⁽⁶⁾⁽⁷⁾	F _{a 20.000 h}		1200 (270)	3000 (674)	3300 (742)	
Radial force for 30,000 h ⁽⁶⁾⁽⁷⁾	F _{r 30.000 h}		500 (112)	1200 (270)	2100 (472)	
Axial force for 30,000 h ⁽⁶⁾⁽⁷⁾	F _{a 30.000 h}		1200 (270)	3000 (674)	3300 (742)	
Maximum radial force ⁽⁷⁾⁽⁸⁾	F _{r Stat}		900 (202)	2200 (495)	3800 (854)	
Maximum axial force ⁽⁷⁾⁽⁸⁾	F _{a Stat}		1200 (270)	3300 (742)	5200 (1169)	
Tilting moment for 20,000 h ⁽⁶⁾⁽⁸⁾	M _{K 20.000 h}	Nm (lb _f .in)	12 (106)	46 (407)	109 (965)	
Tilting moment for 30,000 h ⁽⁶⁾⁽⁸⁾	M _{K 30.000 h}		11 (97)	40 (354)	96 (850)	

Moment of inertia			PLFE064	PLFE090	PLFE110	p ⁽¹⁾
Mass moment of inertia ⁽²⁾	J	kgcm ² (lb _f .in.s ² 10 ⁻⁴)	0.072 - 0.210 (0.637 - 1.859)	0.406 - 1.164 (3.593 - 10.302)	1.484 - 3.430 (13.135 - 30.358)	1
			0.064 - 0.130 (0.566 - 1.151)	0.356 - 0.666 (3.151 - 5.895)	1.377 - 2.407 (12.187 - 21.304)	2

(1) Number of stages
 (2) The ratio-dependent values can be retrieved in Tec Data Finder – www.neugart.com
 (3) T_{min} = -40°C. Optimal operating temperature max. 50°C
 (4) Sound pressure level from 1 m, measured on input running at n_i=3000 rpm no load; i=5
 (5) Max. motor weight* in kg = 0.2 × M_b / motor length in m
 * with symmetrically distributed motor weight
 * with horizontal and stationary mounting
 (6) These values are based on an output shaft speed of n₂=100 rpm
 (7) Based on the end of the output shaft
 (8) Other (sometimes higher) values following changes to T_{2n1}, F_r, F_a, cycle, and service life of bearing. Application specific configuration with NCP – www.neugart.com

Output torques			PLFE064	PLFE090	PLFE110	i ⁽¹⁾	p ⁽²⁾				
Nominal output torque ⁽³⁾	T _{2N}	Nm (lb _r .in)	28 (248)	85 (752)	115 (1018)	3	1				
			38 (336)	115 (1018)	155 (1372)	4					
			40 (354)	110 (974)	195 (1726)	5					
			25 (221)	65 (575)	135 (1195)	7					
			18 (159)	50 (443)	120 (1062)	8					
			15 (133)	38 (336)	95 (841)	10					
			44 (389)	130 (1151)	240 (2124)	9	2				
			44 (389)	120 (1062)	260 (2301)	12					
			44 (389)	110 (974)	230 (2036)	15					
			44 (389)	120 (1062)	260 (2301)	16					
			44 (389)	120 (1062)	260 (2301)	20					
			40 (354)	110 (974)	230 (2036)	25					
			44 (389)	120 (1062)	260 (2301)	32					
			40 (354)	110 (974)	230 (2036)	40					
			18 (159)	50 (443)	120 (1062)	64					
			15 (133)	38 (336)	95 (841)	100					
			Max. output torque ⁽⁴⁾	T _{2max}	Nm (lb _r .in)	45 (398)		136 (1204)	184 (1629)	3	1
						61 (540)		184 (1629)	248 (2195)	4	
64 (566)	176 (1558)	312 (2761)				5					
40 (354)	104 (920)	216 (1912)				7					
29 (257)	80 (708)	192 (1699)				8					
24 (212)	61 (540)	152 (1345)				10					
70 (620)	208 (1841)	384 (3399)				9	2				
70 (620)	192 (1699)	416 (3682)				12					
70 (620)	176 (1558)	368 (3257)				15					
70 (620)	192 (1699)	416 (3682)				16					
70 (620)	192 (1699)	416 (3682)				20					
64 (566)	176 (1558)	368 (3257)				25					
70 (620)	192 (1699)	416 (3682)				32					
64 (566)	176 (1558)	368 (3257)				40					
29 (257)	80 (708)	192 (1699)				64					
24 (212)	61 (540)	152 (1345)				100					

PLFE

⁽¹⁾ Ratios (i=n₁/n₂)

⁽²⁾ Number of stages

⁽³⁾ Application specific configuration with NCP – www.neugart.com

⁽⁴⁾ 30,000 rotations of the output shaft permitted; see page 142

Output torques			PLFE064	PLFE090	PLFE110	$i^{(1)}$	$p^{(2)}$
Emergency stop torque ⁽³⁾	T_{2Stop}	Nm (lb _f .in)	66 (584)	180 (1593)	390 (3452)	3	1
			88 (779)	240 (2124)	520 (4602)	4	
			80 (708)	220 (1947)	500 (4425)	5	
			80 (708)	178 (1575)	340 (3009)	7	
			80 (708)	190 (1682)	380 (3363)	8	
			80 (708)	200 (1770)	480 (4248)	10	
			88 (779)	260 (2301)	500 (4425)	9	2
			88 (779)	240 (2124)	520 (4602)	12	
			88 (779)	220 (1947)	500 (4425)	15	
			88 (779)	240 (2124)	520 (4602)	16	
			88 (779)	240 (2124)	520 (4602)	20	
			80 (708)	220 (1947)	500 (4425)	25	
			88 (779)	240 (2124)	520 (4602)	32	
			80 (708)	220 (1947)	500 (4425)	40	
			80 (708)	190 (1682)	380 (3363)	64	
			80 (708)	200 (1770)	480 (4248)	100	

Input speeds			PLFE064	PLFE090	PLFE110	$i^{(1)}$	$p^{(2)}$				
Average thermal input speed at T_{2N} and S1 ⁽⁴⁾⁽⁵⁾	n_{1N}	rpm	3950 ⁽⁶⁾	2800 ⁽⁶⁾	2350 ⁽⁶⁾	3	1				
			4500 ⁽⁶⁾	3000 ⁽⁶⁾	2550 ⁽⁶⁾	4					
			4500 ⁽⁶⁾	3550 ⁽⁶⁾	2700 ⁽⁶⁾	5					
			4500	4000	3500 ⁽⁶⁾	7					
			4500	4000	3500 ⁽⁶⁾	8					
			4500	4000	3500	10					
			4500 ⁽⁶⁾	4000 ⁽⁶⁾	2850 ⁽⁶⁾	9	2				
			4500	4000 ⁽⁶⁾	3100 ⁽⁶⁾	12					
			4500	4000	3500 ⁽⁶⁾	15					
			4500	4000	3500 ⁽⁶⁾	16					
			4500	4000	3500 ⁽⁶⁾	20					
			4500	4000	3500	25					
			4500	4000	3500	32					
			4500	4000	3500	40					
			4500	4000	3500	64					
			4500	4000	3500	100					
			Max. mechanical input speed ⁽⁴⁾	n_{1Limit}	rpm	13000		7000	6500		

(1) Ratios ($i=n_1/n_2$)
 (2) Number of stages
 (3) Permitted 1000 times
 (4) Application-specific speed configurations with NCP – www.neugart.com
 (5) See page 142 for the definition
 (6) Average thermal input speed at 50% T_{2N} and S1

PLFE064
PLFE090

PLFE110

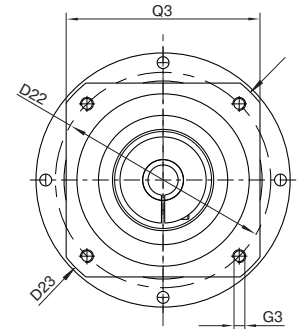
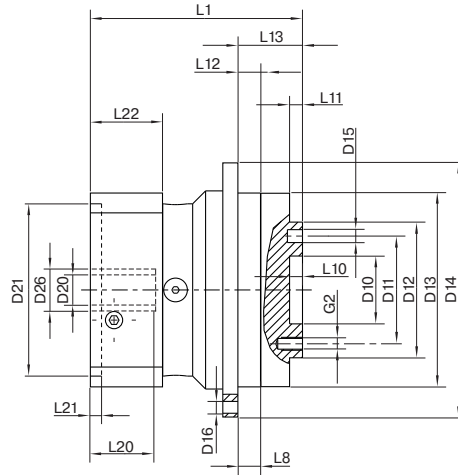
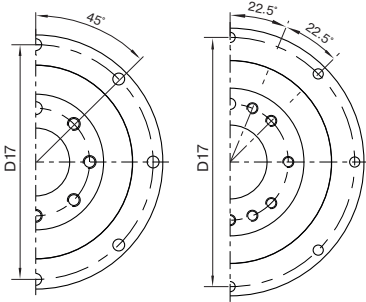

Drawing corresponds to a PLFE090 / 1-stage / flange output shaft with dowel hole / 19 mm clamping system / motor adaptation – one part / B5 flange type motor

All other variants can be retrieved in the Tec Data Finder at www.neugart.com

Geometry ⁽¹⁾			PLFE064	PLFE090	PLFE110	z ⁽²⁾	Code		
Centering diameter output shaft	D10	H7	20 (0.787)	31.5 (1.240)	40 (1.575)				
Pitch circle diameter output shaft	D11		31.5 (1.240)	50 (1.969)	63 (2.480)				
Centering diameter output shaft	D12	h7	40 (1.575)	63 (2.480)	80 (3.150)				
Centering diameter output flange	D13		64 (2.520)	90 (3.543)	110 (4.331)				
Flange diameter output	D14		86 (3.386)	118 (4.646)	145 (5.709)				
Mounting bore output	D16		4.5 8x45°	5.5 8x45°	5.5 8x45°				
Pitch circle diameter output flange	D17		79 (3.110)	109 (4.291)	135 (5.315)				
Min. total length	L1		69 (2.717)	98.5 (3.878)	125.5 (4.941)	1			
			81.5 (3.209)	116 (4.567)	152.5 (6.004)	2			
Flange thickness output	L8		4 (0.157)	7 (0.276)	8 (0.315)				
Centering depth output shaft	L10		4 (0.157)	6 (0.236)	6 (0.236)				
Centering depth output shaft	L11		3 (0.118)	6 (0.236)	6 (0.236)				
Centering depth output flange	L12		7.5 (0.295)	10.5 (0.413)	10.5 (0.413)				
Output flange length	L13		19.5 (0.768)	30 (1.181)	29 (1.142)				
Clamping system diameter input	D26		More information on page 131						
Motor shaft diameter j6/k6	D20		The dimensions vary with the motor/gearbox flange. The input flange dimensions can be retrieved for each specific motor in Tec Data Finder at www.neugart.com						
Max. permis. motor shaft length	L20								
Min. permis. motor shaft length									
Centering diameter input	D21								
Centering depth input	L21								
Pitch circle diameter input	D22								
Motor flange length	L22								
Diagonal dimension input	D23								
Mounting thread x depth	G3	4x							
Flange cross section input	Q3	■							
Flange output shaft with dowel hole (EN ISO 9409-1)									E
Dowel hole x depth	D15	H7				5x6	6x7	6x7	
Number x thread x depth	G2					7 x M5x7	7 x M6x10	11 x M6x12	

⁽¹⁾ Dimensions in mm (in)

⁽²⁾ Number of stages